



Established 1958

Thermal-Disc™ Steam Traps Series TA-TD

Operation

Tunstall Corporation produces a full line of Thermal-Disc™ Steam Traps. Available in 3/8", 1/2", 3/4" and 1" NPT connections, all the internal parts are stainless steel for long service life.

The Tunstall Thermal-Disc™ operates using Bernoulli's Theorem; as condensate enters the Thermal-Disc™ Trap, it lifts the thermal disc and discharges through outlet ports. Multiple outlet ports assure that the lift of the disc is parallel to the seat for efficient operation. Once the condensate reaches its flash point, the pressure on the top of the disc increases, due to higher velocity steam, causing the disc to snap closed. As the steam above the disc condenses, pressure above the disc will lower, and allow the disc to lift again and repeat the process.

Features

- In-Line Connection
- Compact Size
- High Strength Stainless Steel Construction
- Low Maintenance (Only one moving part)
- Can be installed Vertically for "Freeze Proof" installation

Applications

- Steam Main Drainage
- High Pressure Drips
- Tracer Lines
- Process Equipment
- Laundry Equipment
- Kitchen Equipment
- Superheated Steam applications
- Outdoor installations subject to freezing



Materials of Construction

Body	Stainless Steel AISI 420F
Cap	Stainless Steel AISI 416
Disc	Stainless Steel AISI 420



Tunstall Corporation
118 Exchange Street · Chicopee, MA 01013

© August 2014

We reserve the right to alter designs, specifications and information without notice.

Phone (413) 594-8695 · Fax (413) 598-8109
www.maconbalancing.com

Bulletin-TA-Series-TA-TD-0814
Thermal-Disc & Thermostatic Traps

Thermal-Disc™ Steam Traps - Series TA-TD

Engineering Specifications

Installation

Valve installation is typically in the horizontal position as close to the equipment being drained as possible. A 20 mesh strainer is recommended upstream of the trap as is an isolation valve. Piping to and from the trap should be equal to the trap connection (one size larger is acceptable). Body material is not suitable for welding.

Freeze proof installation is achieved by installing the trap vertically, discharging downward. All drains must be pitched towards the trap. Discharge piping must be self-draining.

Pressure / Temperature Rating

PMA - Max. Allowable Pressure: 600 psi
 TMA - Max. Allowable Temperature: 800° F
 PMO - Max. Operating Pressure: 600 psi
 TMO - Max. Operating Temperature: 800° F

Capacities - lbs. of condensate/hr

Inlet (psig)	TA-TD-38	TA-TD-50	TA-TD-75	TA-TD-100
3.5	180	300	415	650
5	185	315	430	680
10	190	350	475	740
15	195	380	520	815
20	200	415	565	885
25	215	440	610	940
30	220	470	650	1000
40	230	515	720	1080
50	250	580	825	1225
75	310	710	1020	1500
100	375	825	1185	1800
150	500	1020	1480	2215
200	620	1165	1710	2625
250	710	1300	1950	2935
300	800	1440	2110	3300
350	825	1565	2265	3600
400	900	1670	2490	3875
450	1070	1775	2625	4120
500	1120	1880	2780	4350
550	1185	1960	2985	4560
600	1290	2060	3140	4840

NOTE: Max. back pressure should not exceed 80% of the inlet pressure under any conditions of operation, otherwise the trap may not shut.

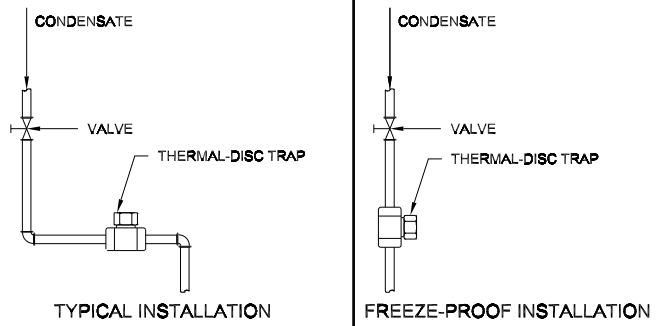
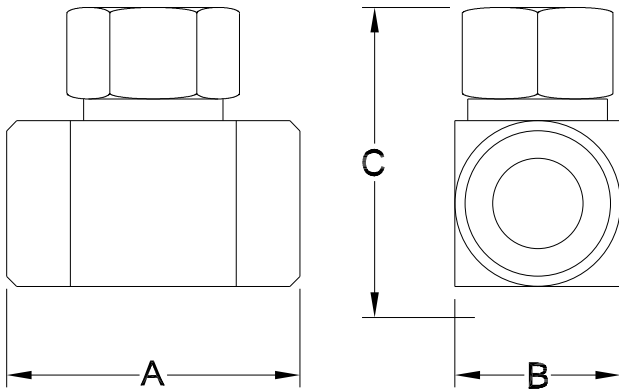

Dimensions and Weights						Repair Kit
Model	Size	A	B	C	Weight	
TA-TD-38	3/8"	1-3/8	2	1-11/16	0.75	TA-TD-DISC-38
TA-TD-50	1/2"	1-1/2	2-11/16	2	1.25	TA-TD-DISC-50
TA-TD-75	3/4"	1-3/4	2-13-16	2-3/8	2.00	TA-TD-DISC-75
TA-TD-100	1"	2-1/8	3-3/16	2-13/16	3.00	TA-TD-DISC-100

Note: Dimensions in inches & Weights in pounds

